

SIKAPROOF A PILE CAP WATERPROOFING (OPTION 2) GAS & WATERPROOFING

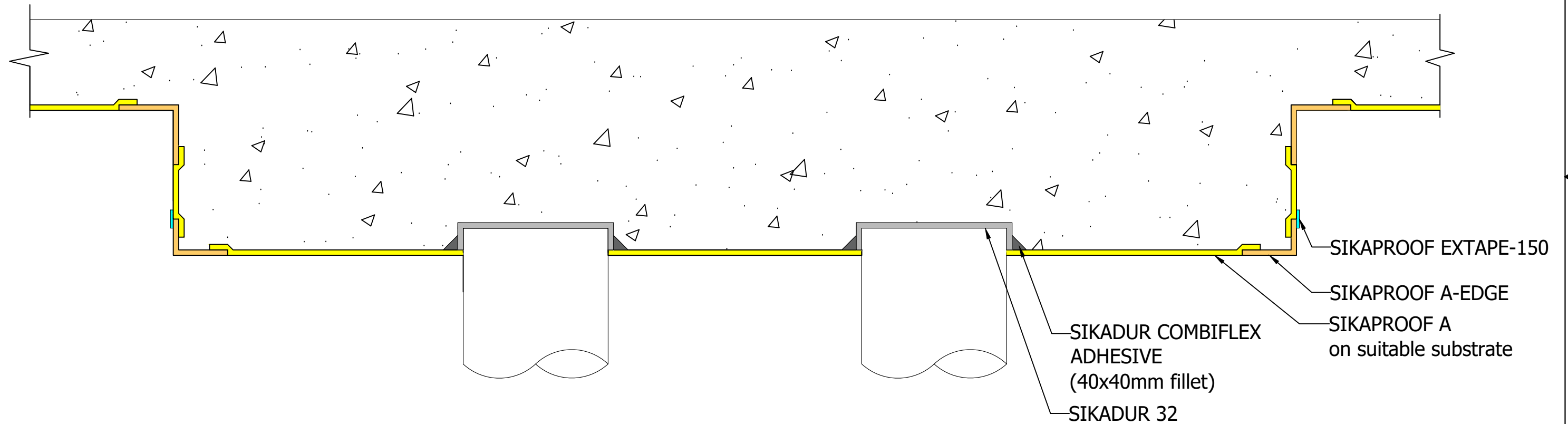

A DRAWINGS MUST ALWAYS BE REVIEWED BY A DESIGN SPECIALIST AND IF NECESSARY MODIFIED TO ENSURE SUITABILITY FOR THE SPECIFIC APPLICATION.

The information contained herein and any other advice are given in good faith based on Sika's current knowledge and experience of the products when properly stored, handled and applied under normal conditions in accordance with Sika's recommendations. The information only applies to the application(s) and product(s) expressly referred to herein and is based on laboratory tests which do not replace practical tests. In case of changes in the parameters of the application, such as changes in substrates etc., or in case of a different application, consult Sika's Technical Service prior to using Sika products. The information contained herein does not relieve the user of the products from testing them for the intended application and purpose. All orders are accepted subject to our current terms of sale and delivery. Users must always refer to the most recent issue of the local Product Data Sheet for the product concerned, copies of which will be supplied on request.

**ALL DIMENSIONS ARE IN MM
UNLESS STATED
DO NOT SCALE FROM
DRAWING**

THIS DRAWING IS THE
CONFIDENTIAL PROPERTY OF SIKA
LIMITED AND MUST NOT BE
REPRODUCED EITHER WHOLLY OR
PARTLY. ALL RIGHTS IN RESPECT OF
PATENTS, DESIGN AND COPYRIGHTS
ARE RESERVED. SIKA LTD.
WWW.SIKA.CO.UK



| | | | |
|---|--------------------------------|---------------------------------|------------------|
| Drawn by <i>A. O'Ferrall</i> | Checked by <i>D. Clifff</i> | Approved by <i>A. Burman</i> | Date 29/06/18 |
| Description SIKAPROOF A PILE CAP WATERPROOFING (OPTION 2) GAS & WATERPROOFING | | | |
| Drawing No. SPA31 | | Issue B | Sheet 1 / 1 |

D
C
B
A

D
C
B
A

6 | 5 | 4 | 3 | 2 | 1

6 | 5 | 4 | 3 | 2 | 1